

REV.	ZONE	LTR	DESCRIPTION	DATE	REVISER	APPD
------	------	-----	-------------	------	---------	------

A
B
C
D
E

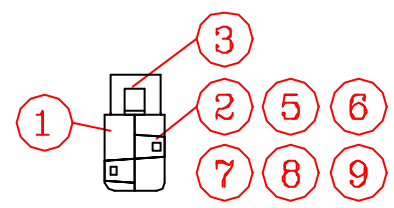
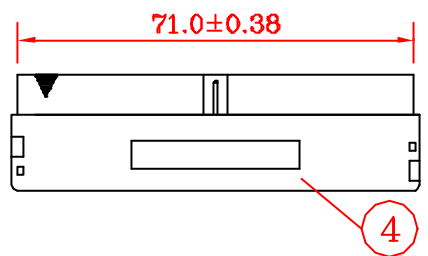
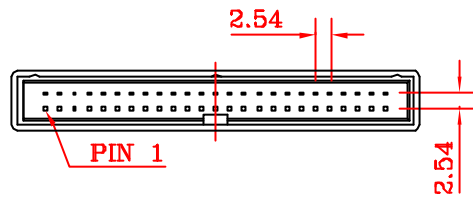
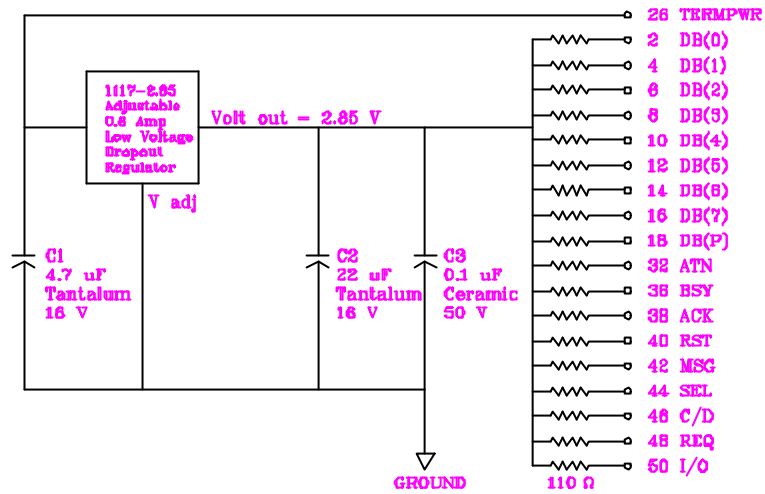

NOTE :

1. Pins 25 not Connected.
2. Resistor tolerance is $\pm 2\%$.
3. H-SAX type.
4. SCSI single-end active internal terminator.

PACKING LIST		1 PIECE IN A PAPER BOX CARTON MEAS'T: 33cm * 25cm * 41cm		
PART NUMBER	TYPE	QUANTITY	NET WEIGHT	GROSS WEIGHT
F50D11-A		200	6 KGS.	7 KGS.

Tolerance= $\pm 2\%$	1	Regalutor,1117 SMD.	9	XQT-053
Tantalum	1	Capacity,4.7uF,SMD.	8	XQT-051-S47
Tantalum	1	Capacity,22uF,SMD.	7	XQT-051-S22C
Ceramic	1	Capacity,0.1uF	6	XQT-048-01
Tolerance= $\pm 2\%$	2	Resistor,110 Ω	5	XQT-044-A
Color= Black	1	Term. cover stop	4	XPL-084
Black G/F	1	Box header 50P 180°	3	HTZ50D-17
	1	PCB for Box header	2	XPL-085-PAG
Color= Black	2	Term. Cover	1	XPL-083

REMARK	Q'TY	PART NAME	NO.	PART NO.
		高位企業有限公司 Yes Way Enterprise Corp.		TOLERANCE UNSPECIFIED
		SCALE	UNIT	.000 \pm
		1 : 1	mm	.00 \pm
				.0 \pm
				\pm
				ANGLE \pm
NAME		SHEET		DRAWN
SCSI ACTIVE		1		Vivian 7/27/2K
TERMINATOR		1		DESIGNER
				Simen
DRAWING NO.		REV	CHECKED	
F50D11-A		1.1	Ruby	
			APPROVED	
			Gena	
		A3		